

THIS DRAWING IS UNPUBLISHED. RELEASED FOR PUBLICATION, 19 .
 © COPYRIGHT 19 BY AMP INCORPORATED. ALL INTERNATIONAL RIGHTS RESERVED.

| LOC | DIST | P | F | ZONE | LTR | REVISIONS | DATE | APPD |
|-----|------|---|---|------|-----|-------------------|---------|-------|
| CE | 16 | | | | 0 | REL PER NPR 95-59 | 2-10-95 | BB/TF |

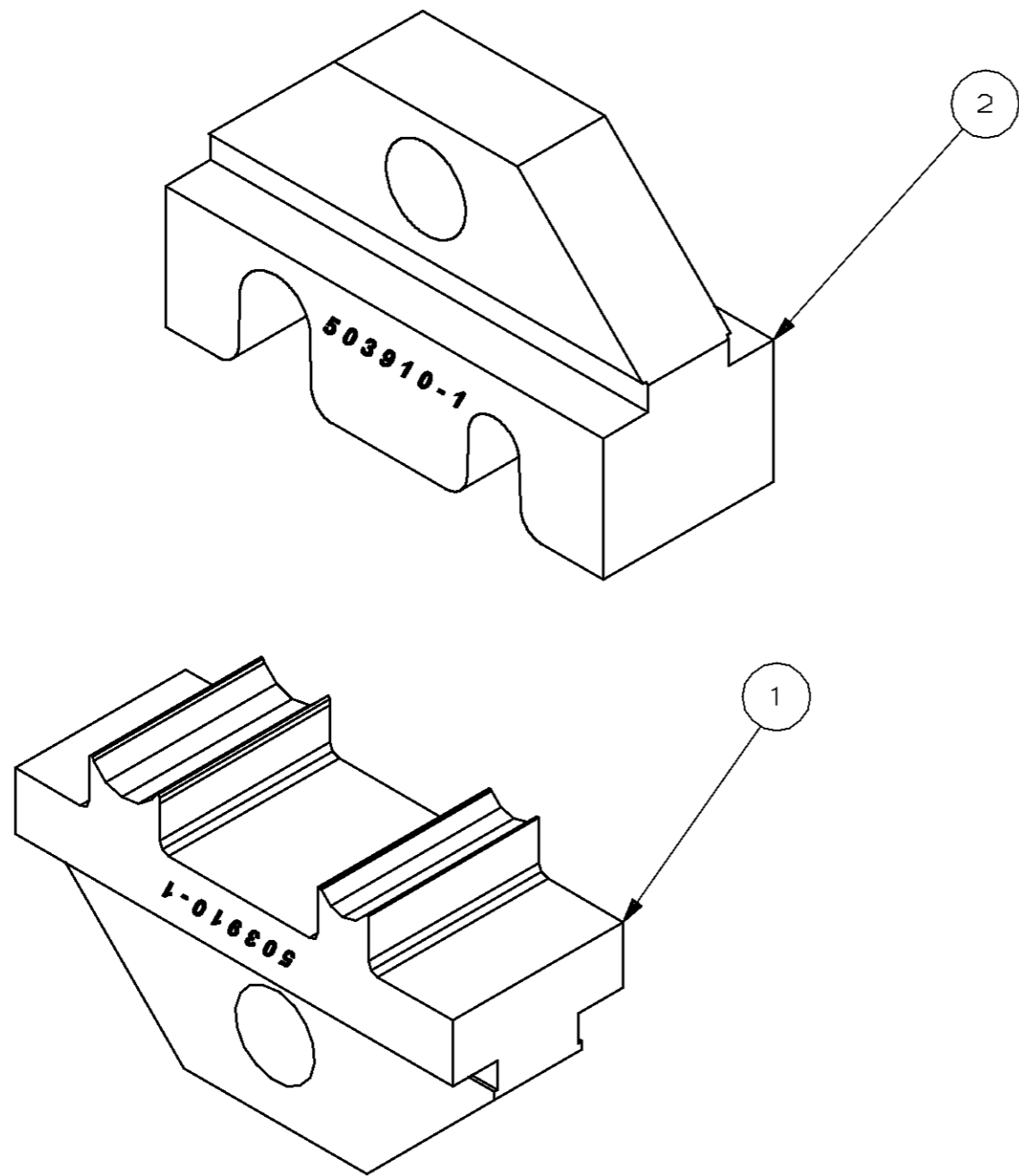

| ITEM NO | DESCRIPTION | ITEM NO |
|---------|----------------------|---------|
| 1 | INDENTER, CRIMP TOOL | 2 |
| 1 | ANVIL, CRIMP TOOL | 1 |
| -1 | DESCRIPTION | ITEM NO |

| | | | |
|---|---------------------------|--|------------------|
| DO NOT SCALE PRINT. UNLESS SPECIFIED DIMENSIONS IN INCHES TOLERANCES ON: 2 PLC DEC ± - 3 PLC DEC ± - ANGLES ± - | DR 2-10-95 B.BRIGGS | AMP AMP INCORPORATED Harrisburg, Pa. 17105 | |
| | CHK 2-10-95 B.BRIGGS | | |
| | APPD 2-10-95 T.FANCETT | NAME DIESET, PROCRIMPER, AMP SC AND 2.5mm THREADED | |
| | APPD 2-14-95 D.STAKEM | SIZE B | FSCM NO 00779 |
| MATERIAL - | PRODUCT SPEC - | SCALE 4:1 | |
| FINISH - | APPLICATION SPEC - | SHEET 1 OF 1 | |
| | WEIGHT - | | |